

|          |    |    |    |    |    |    |    |    |    |    |    |    |    |    |    |    |    |    |    |    |    |    |    |    |    |    |    |    |    |
|----------|----|----|----|----|----|----|----|----|----|----|----|----|----|----|----|----|----|----|----|----|----|----|----|----|----|----|----|----|----|
| GEN. ST. | 01 | 02 | 03 | 04 | 05 | 06 | 07 | 08 | 0D | 50 | 60 | 70 | 80 | 90 |    |    |    |    |    |    |    |    |    |    |    |    |    |    |    |
| INT. ST. | 10 | 11 | 12 | 13 | 14 | 18 | 20 | 31 | 32 | 33 | 34 | 38 | 39 | 40 | 42 | 43 | 44 | 45 | 46 | 48 | 56 | 70 | 72 | 73 | 76 | 81 | 83 | 84 | 88 |

| REV. | DATE       | DESCRIPTION            | BY     | C'K'D' |
|------|------------|------------------------|--------|--------|
| A    | 2001-09-14 | CONVERSION REVISION 03 | KN     |        |
| B    | 2005-10-26 | I05-0205               | ALEX B | BKP    |
| C    | 2006-08-08 | I06-0144               | ALEX B | BKP    |

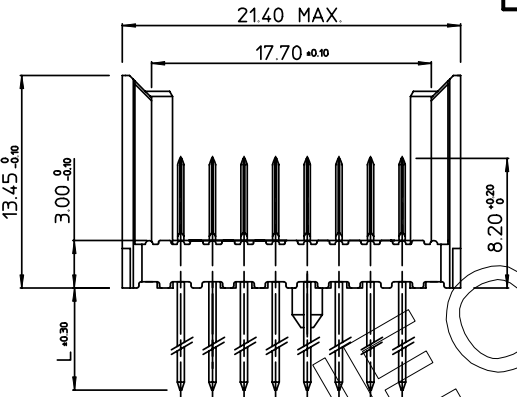
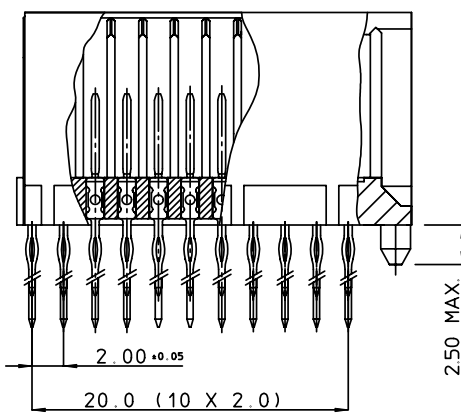

**PERFORMANCE CHARACTERISTICS**

CURRENT RATING : 1.5 A AT 20°C ( FULLY LOADED )  
 1 A AT 70°C ( FULLY LOADED )

RATED VOLTAGE : 500 V AC (CONT / CONT )

OPERATING TEMPERATURE : -55°C TO 125°C

CONTACT RESISTANCE : 20 mΩ MAX

INSERTION FORCE : 0.60 N MAX / CONT

EXTRACTION FORCE : 0.15 N MIN / CONT

INSULATION RESISTANCE : 10<sup>4</sup> MΩ MIN

| CAT. NR.         | L ±0.3 | DESCRIPTION           |
|------------------|--------|-----------------------|
| HM2P89PD8110---- | 3.7    | SHORT PRESS-FIT       |
| HM2P89PC8110---- | 4.5    | SHORT PRESS-FIT       |
| HM2P89PK8110---- | 13     | REAR PLUG-UP: LEVEL 1 |
| HM2P89PM8110---- | 14.5   | REAR PLUG-UP: LEVEL 2 |
| HM2P89PN8110---- | 16     | REAR PLUG-UP: LEVEL 3 |
| HM2P89PT8110---- | 13     | WIRE WRAP             |

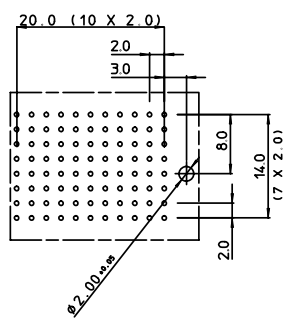
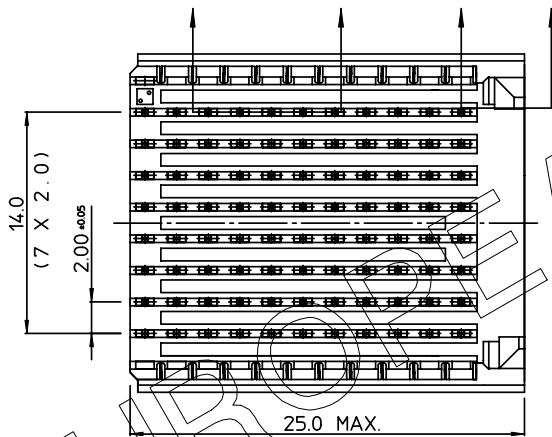

LAY-OUT  
P.C.B. - HOLE

**NOTES**

1. \*HM2P89P#8110<sup>C</sup>\*  
 PERFORMANCE LEVEL INDICATOR  
 (REFER DWG No. BS.C ,201844,003)  
 LEAD FREE INDICATOR : LF-LEAD FREE  
 (DIGIT 15&16)
2. THIS PRODUCT IS CSA APPROVED.  
 THIS PRODUCT IS UL RECOGNIZED.
3. FOR RECOMMENDED PTH DIMENSIONS REFER DRAWING : BS.A ,201572,001
4. THE PRODUCT (LF) MEETS EUROPEAN UNION DIRECTIVES AND OTHER COUNTRY REGULATIONS AS DESCRIBED IN GS-22-008

**MALE SIGNAL STRAIGHT PRESS-FIT-TO-BOARD CONNECTOR  
EXTENSION MODULE (WIDE BODY)**

|   |               |             |              |  |
|---|---------------|-------------|--------------|--|
| 1DEC ±0.2<br>2DEC ±0.1<br>ANGLES ±1°  | <b>APPR.</b>  | <b>DATE</b> | <b>SIGN.</b> | MILLIPACS 2 / TYPE F (8 ROW) / NO SHIELDING  |
|   | DRAFT         | 1996-04-30  | W.Panle      | <b>CAT. No.</b> HM2P89P#8110----   |
|   | CHECKED       |             |              |  |
| WE RESERVE THE RIGHT TO CHANGE DIMENSIONS OR REQUIREMENTS WITHOUT PRIOR NOTICE. | PROD. MGR.    |             |              |  www.fciconnect.com |
|   | PR. ENG. MGR. |             |              |  |
| ALL DIMENSIONS IN MM  | PR. MGT. MGR. |             |              |  |

**REFERENCES**

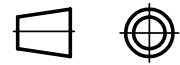

BS.C ,202259,003 C

THIS IS OUR EXCLUSIVE PROPERTY. IT IS NOT TO BE COPIED, REPRINTED OR DISCLOSED TO A THIRD PARTY. NOR USED FOR MANUFACTURING WITHOUT OUR WRITTEN CONSENT, AND HAS TO BE RETURNED TO US IN CASE OF NO USAGE

DIT IS ONZE EIGENDOM EN MAG NOCH NAGEMAAKT. HERDRUKT, OVERGEMAAKT AAN DERDEN, NOCH VOOR FABRIKATIE GEBRUIKT WORDEN, ZONDER ONZE SCHRIFTELIJKE TOELATING. BIJ NIET GEBRUIK IS TERUGZENDING VERPLICHT.